

RTA/RTD - Single & Dual Range Torque Transducers

Product Overview

The RTA and RTD Torque Transducers provide accurate Torque measurement at speeds of up to 50,000rpm. The series has integral signal conditioning providing a $\pm 5V$ output and they also provide 60 TTL pulses for additional Speed measurement. For speeds below 7000rpm, a 360-pulse option is also available.

The RTA and RTD series of single and dual range Torque Transducers have turndown ratios of 10:1 or 5:1. RS232 communications is an added option, along with a range of digital readouts for Torque, Speed and Power if required.

System Specifications:

Full scale output:	0 \pm 5V	Accuracy (RTA):	< \pm 0.1% fs
Operating Temp:	0 to +70°C	Overload Capacity:	150% fs
RTD lower scale:	< \pm 0.2%fs	Storage Temp:	-25 to +80°C
Supply Voltage:	11 to 30VDC	Repeatability:	\pm 0.02% fs
Zero Shift:	< \pm 0.005%/C°	Power input (approx.):	2.5W
Maximum frequency:	1 kHz	Span Shift:	< \pm 0.01%/C°

Industrial Measurements Ltd

Watling Drive
Sketchley Meadows
Hinckley LE10 3EY
Tel: +44(0) 1332 810 240
sales@indmeas.co.uk
www.indmeas.co.uk



Model RTA/RTD	Rated Torque (Nm)	Std. Max Speed	Option Max Speed	Stiffness (Nm/rad)	Model RTA/RTD	Rated Torque (Nm)	Std. Max Speed	Option Max Speed	Stiffness (Nm/rad)
0.2	0.2	20000	50000	40	50	50	12000	30000	9100
0.5	0.5	20000	50000	40	100	100	12000	30000	13500
1	1.0	20000	50000	230	200	200	8000	20000	60000
2	2.0	20000	50000	350	500	500	8000	20000	100000
5	5.0	20000	50000	450	1000	1000	8000	20000	135000
10	10	20000	50000	700	2000	2000	5000	10000	520000
20	20	20000	50000	800	5000	5000	5000	10000	720000

Dimensions

Dimensions are the same for both the standard and high-speed units. Sizes up to and including the RT100 have keyless shafts requiring clamp-type couplings. Larger sizes have twin metric keys to BS4235/DIN6885.

MODEL	L	L1	L2	d (g6)	D	A	B	G	H	M	T	TK
RTA/D 0,2 – 0,5	160.5	16	16	9	58	23.5	19	122	51	M5	10	46
RTA/D 1,0	159	16	16	9	58	22	17.5	122	51	M5	10	46
RTA/D 2 – 5	163	18	18	10	58	24	19.5	122	51	M5	10	46
RTA/D 10 - 20	166	20	20	12	58	25	20.5	122	51	M5	10	46
RTA/D 50 - 100	180	28	28	22	78	43.5	34	113	66	M6	12	64
RTA/D 200-1000	267	60	61	42	98	83.5	64.5	137	78	M6	12	87
RTA/D 2000-5000	418	120	120	70	148	-	-	-	-	M8	16	132

RTA/RTD 0.2 - 100

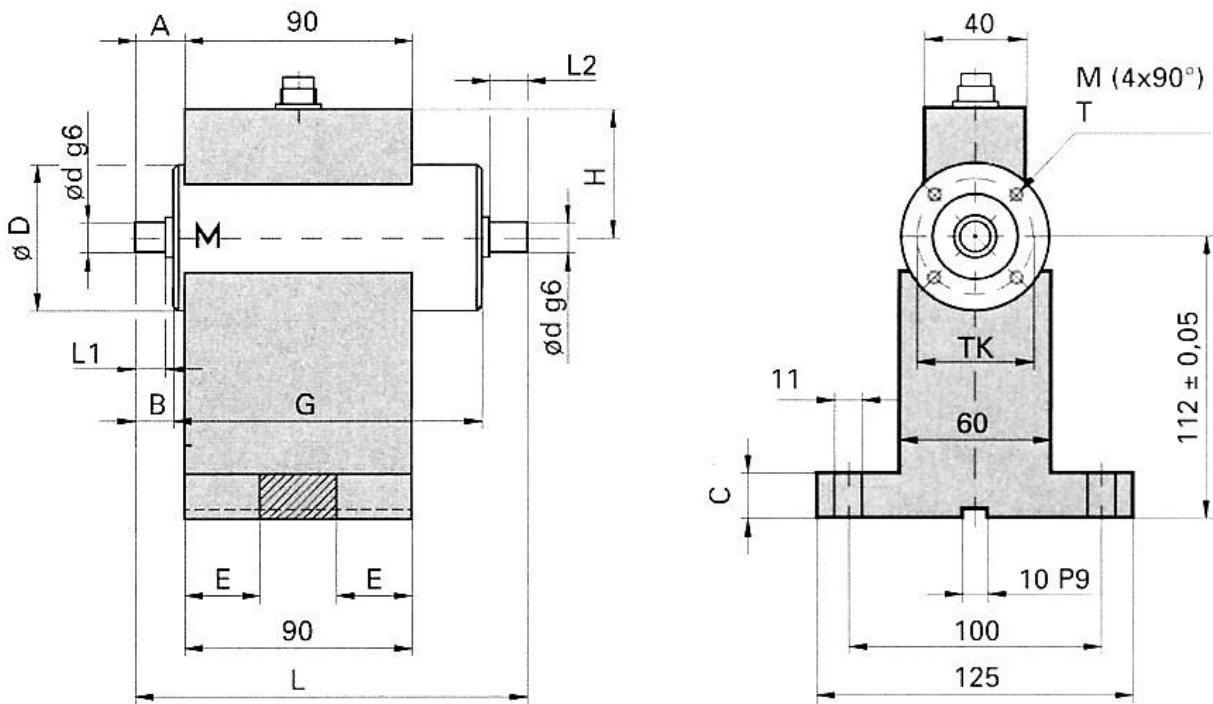

RTA/RTD 200 - 1000

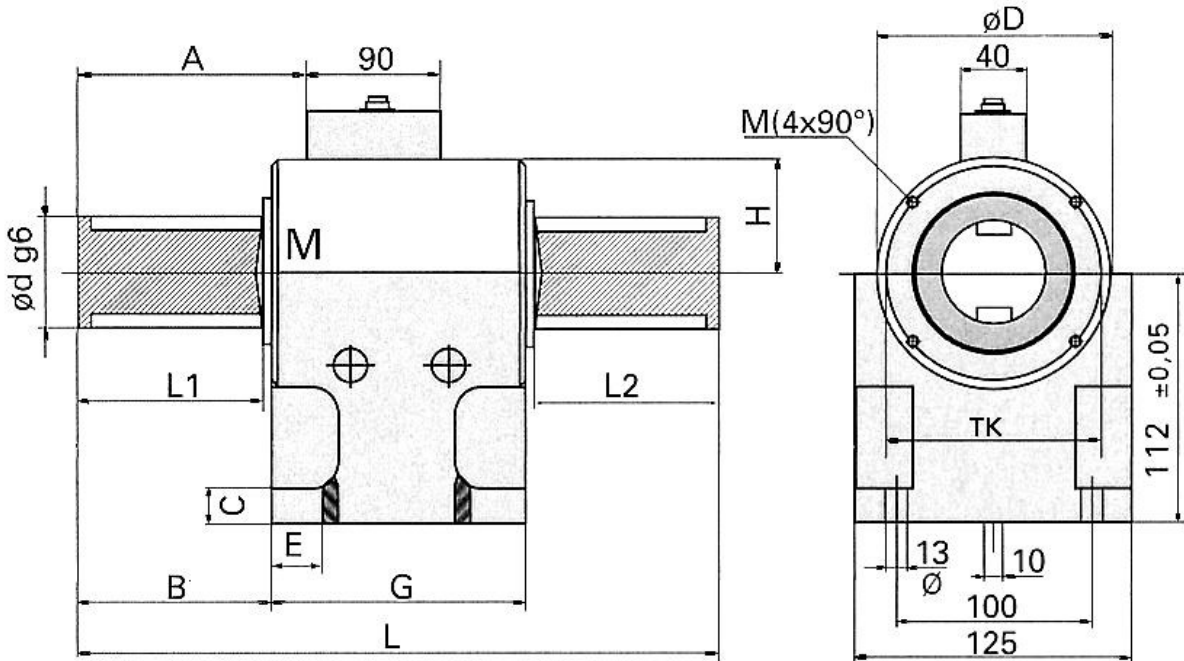

RTA/RTD 2000 - 5000

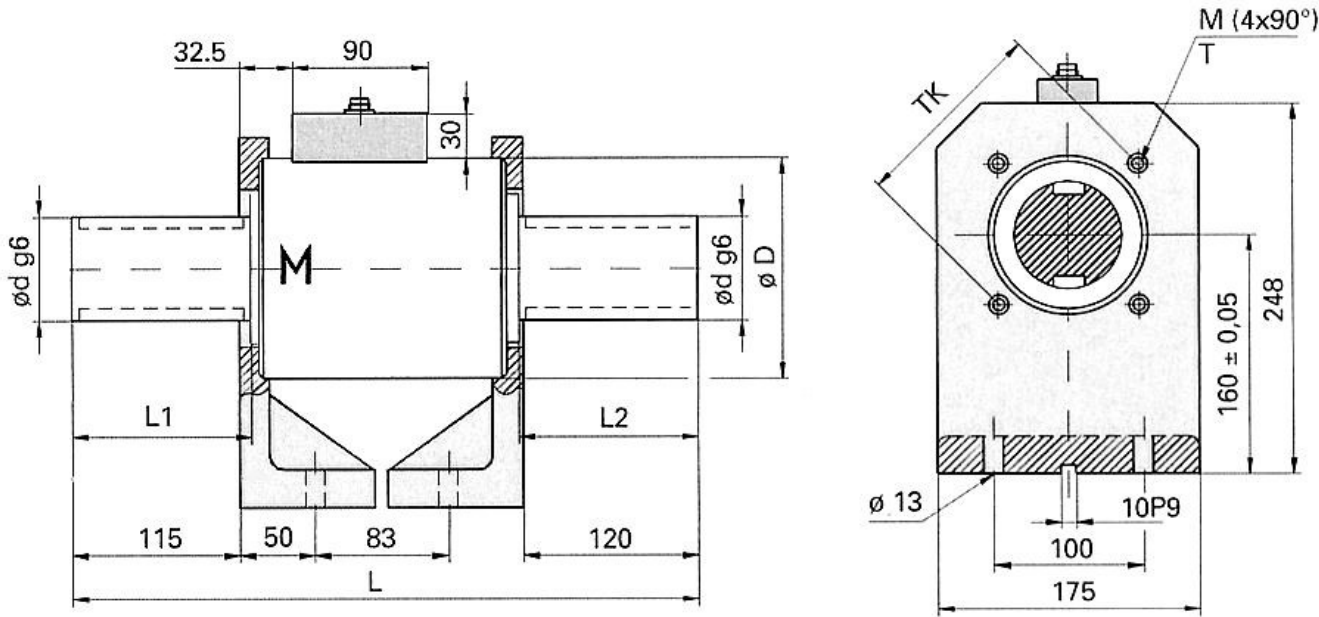

Industrial Measurements Ltd
 Watling Drive
 Sketchley Meadows
 Hinckley LE10 3EY
 Tel: +44(0) 1332 810 240
 sales@indmeas.co.uk
 www.indmeas.co.uk



Wiring Details

PIN	Designation		
A	GND relating to +V supply	G	TTL Level
B	TXD (UMV readout)	H	Open collector output
C	V out $\pm 5V$ for rated Torque $\pm 5V$ for cal result	J	N/C
D	AGND relating to V out	K	Calibration Off: 0 to 2V On: 3.5 to 24V
E	DGND relating to Speed/Cal	L	RXD
F	+V supply 11 - 30Vdc, 2.5W	M	Screen in sensor to housing

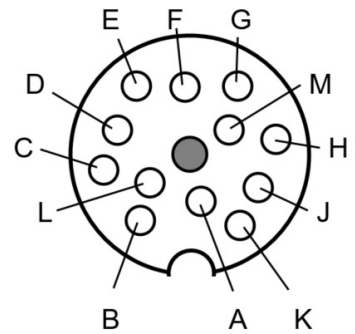

RTD only

PIN	Designation
1	Range activation
2	N/C
3	N/C
4	N/C
5	TXD (user RS232 option)
6	RXD (user RS232 option)
7	DGND

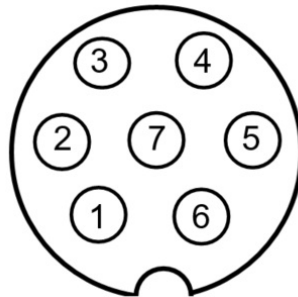

For more information about the RTA/D range or for a quote, call +44 (0) 1332 810 240 or email sales@indmeas.co.uk.

IML, providing custom torque solutions

Industrial Measurements Ltd
 Watling Drive
 Sketchley Meadows
 Hinckley LE10 3EY
 Tel: +44(0) 1332 810 240
sales@indmeas.co.uk
www.indmeas.co.uk

