

TFC/TFD - Coupling based Torque Transducer

Product Overview

Strain Gauges are built into a coupling spacer with proprietary flexible elements, adaptor rings and hubs to provide a complete Torque measuring unit. The sealed data transmission system can be used in the presence of water, oil, grease and dust.

No bearings are used so the unit is effectively maintenance-free. Hubs are parallel bored as required before despatch.

System Specifications:

Calibration level:	Specified on certificate	Output signal at zero torque:	10kHz
Overload capacity:	150% FS	Nominal output at +FS torque:	15kHz
Operating temp:	+5 to +65°C	Nominal output at -FS torque:	5kHz
Optional temp:	0 to +100°C	Non-linearity:	±0.2% FS
Zero shift:	<±0.01% FS/°C	Repeatability:	±0.05% FS
Span shift:	<±0.02%FS/°C	Hysteresis:	±0.1% FS

Industrial Measurements
part of Crane Electronics Ltd.
Watling Drive
Sketchley Meadows
Hinckley LE10 3EY
Tel: +44(0) 1332 810 240
sales@indmeas.co.uk
www.indmeas.co.uk



Dimensions

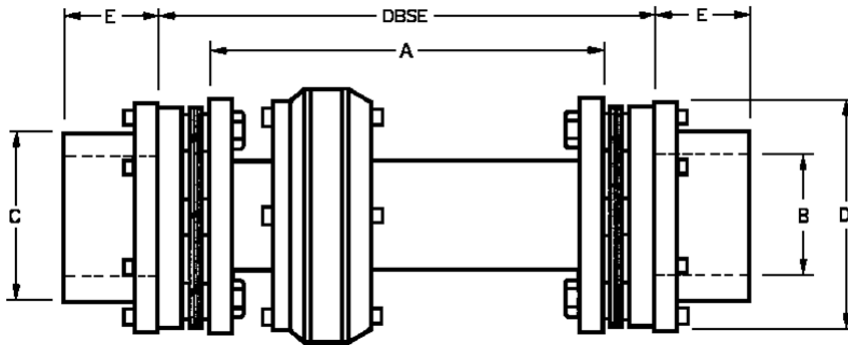

TFC	Rated Torque (Nm)	Max Speed		Min DBSE	ØB (Max)	C	D	E
		Balanced	Unbalanced					
0011	125	25000	7000	190	36	54	86	40
0027	315	20000	6000	215	46	69	105	45
0060	715	16500	5200	240	65	90	130	55

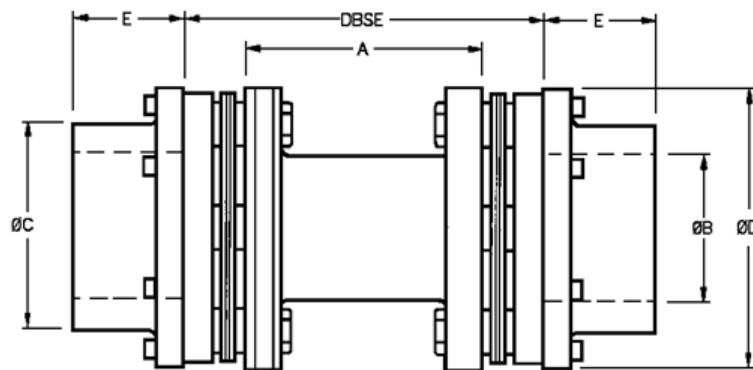

TFC	Rated Torque (Nm)	Max Speed		Min DBSE	ØB (Max)	C	D	E
		Balanced	Unbalanced					
0110	1300	14400	4800	225	80	112	152	62
0180	2100	12000	4400	255	90	131	179	70
0300	2900	15300	5700	255	84	119	155	84
0500	4800	12800	5000	275	100	143	185	100
0750	7000	11300	4600	295	110	161	209	110
1050	10000	10100	4200	315	134	187	235	134
1500	14300	9000	3900	340	148	208	262	148
2000	19000	8200	3700	365	161	225	288	161

5-10-15 kHz standard output, other options are available.

PC's data cards with various software options.

Panel / desk mounted displays with ± 10 vdc, 4 – 12 – 20mA outputs, relays, RS232.



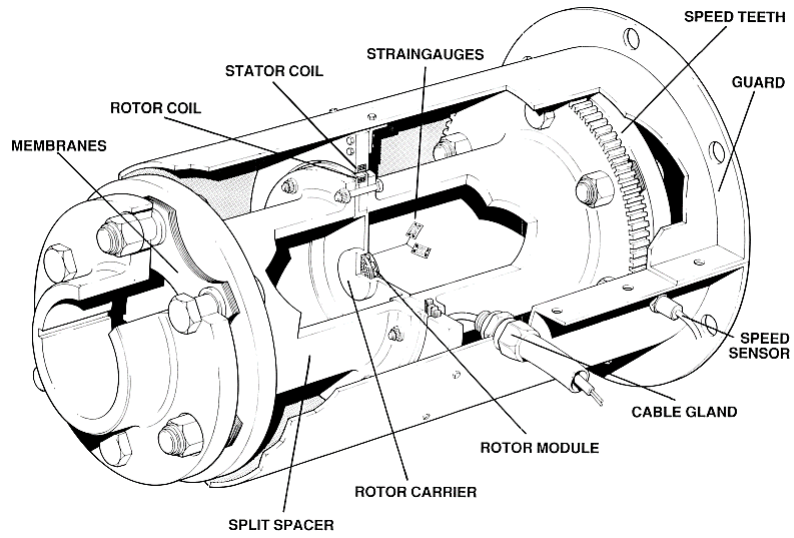

System Schematic

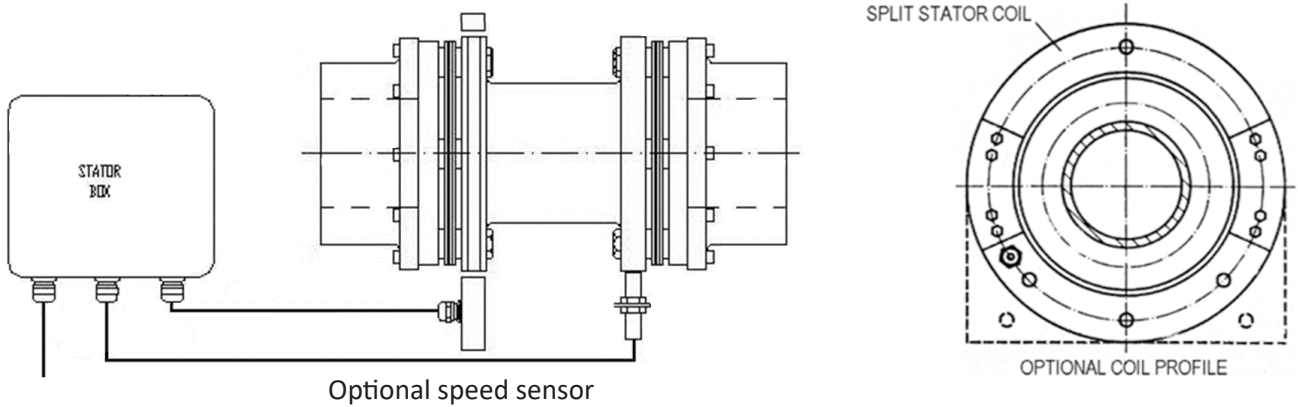

Providing custom torque solutions. Industrial Measurements.

Founded in 1981, Industrial Measurements have been providing comprehensive Torque measurement solutions and the design & manufacture of standard and bespoke Torque Transducers, for over 35 years.

We pride ourselves on being able to provide a solution no matter what the challenge. As well our standard products such as Inline Rotary Torque Transducers & Static Torque Systems, we are devoted to designing and manufacturing completely bespoke Torque systems to suit our customers needs.

As well as offering one of the largest ranges of Torque Transducers in the world, we make special Torque Sensors, Torque Meters and Load Cells. We also provide a fully accredited Torque calibration service, not just for our own products but for other manufacturers Torque products too.

Whilst our head office is based in the UK, we have customers from all over the world, in particular Western Europe and we are always looking to extend our customer base and offer support and technical advice to all current and future customers.

The knowledge and commitment of our dedicated employees has aided in building a quality customer base across the globe and we supply several industries including Marine & Offshore, Steel Plants, Automotive, Aerospace, Power Generation and much more.

Since 2009, Industrial Measurements has been a part of the Crane Group, alongside Crane Electronics Ltd.



For more information about the TFC & TFD or for a quote, call +44 (0) 1332 810 240 or email sales@indmeas.co.uk.

Providing custom torque solutions

Industrial Measurements
part of Crane Electronics Ltd.
Watling Drive
Sketchley Meadows
Hinckley LE10 3EY
Tel: +44(0) 1332 810 240
sales@indmeas.co.uk
www.indmeas.co.uk

